

Townsend Peeler 2800

Perfect cellulose casing removal



The Townsend Peeler 2800 accurately removes the inedible cellulose casing from your cooked and chilled sausages without damaging the sausage itself. The high capacity peeler can handle a wide variety of products, including very small sausages. The successful high capacity machine has been redesigned, according to market requirements.

Key improvements

Key improvements and the use of more durable materials lead to a better performance over a longer time with a lower COO. The new design offers improved access for easy cleaning and maintenance. It also leads to a higher operator satisfaction. The Townsend Peeler 2800 has a very low Cost of Ownership and an attractive ROI.

- High in capacity, low in COO
- Improved easy-access design
- More robust materials and long-life-parts
- Accurate peeling of very small sausages possible

Product dimension and capacity

Diameter	13 – 41 mm	0.5 – 1.6"
Length	> 4 pitch (38 mm)	> 4 pitch (1.5")
Max. capacity	225 m/min	750 ft/min

Dimensions

Length	2163 mm	85.2"
Height	1742 mm	68.6"
Width	666 mm	26.2"
Mass	402 kg	886 lbs

Air system

Pressure	6.9 Bar	100 psi
Consumption	25.5 m ³ /hr	900 ft ³ /hr
Connection	g 3/8 iso	

Steam system

Pressure (recommended)	1.7 Bar	25 psi
Pressure (maximum)	3.4 Bar	50 psi
Consumption	0-5 bhp	0-78 kg/hr
Connection	g 3/8 iso	

Vacuum system

Vacuum	75 mm Hg	40 in H ₂ O
Consumption	305 m ³ /hr	180 ft ³ /min
Connection	51 mm	2"

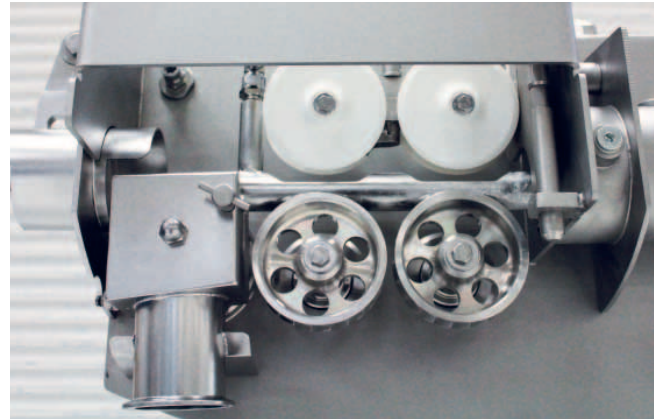

Advantages at a glance...

- More robust materials and long-life-parts for prolonged trouble-free production
- Easier to adjust settings for production optimization
- Easy-access design: easy to clean and maintain
- Tool-less assembly and disassembly

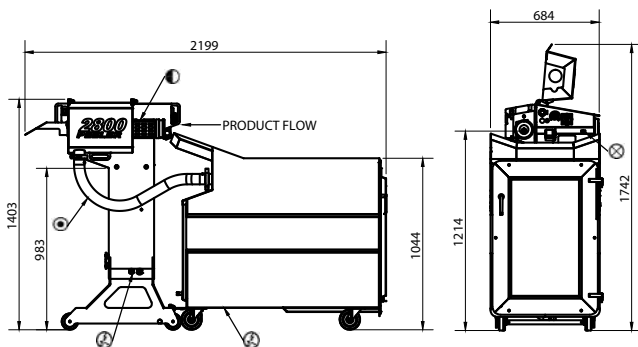

Power supply

Volts	200 V	220 V	380 V	415 V	460 V	575 V
Amps	8.6/12.5	8.78/12.5	4.5/7.2	4.1/7.2	3.4/6.5	2.7/4.8
Fuse	10/20	10/20	7/10	7/10	5/10	5/7
Frequency	60/50 Hz	50 Hz	50 Hz	50 Hz	60 Hz	60 Hz
Cable	8 AWG	8 AWG	10 AWG	10 AWG	10 AWG	10 AWG
Tolerated Voltage	-5/+10%	-5/+10%	-5/+10%	-5/+10%	-5/+10%	-5/+10%

Total Power 1.5/5.22 kW

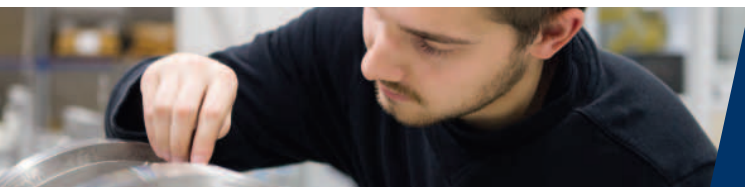

Marel is the leading global provider of advanced equipment and systems for the fish, meat and poultry industries.